

**Practice Manual**

**COMPUTER AIDED DETAILING OF STRUCTURES**

**SUBJECT CODE:  
15CVL77**

**DEPARTMENT OF CIVIL ENGINEERING**

**VISION**

**MISSION**

**DEPARTMENT OF CIVIL ENGINEERING**

**Vision**

**Mission**

**The Program Educational Objectives (PEOs)**

1. Able to apply the knowledge of Engineering to solve construction related problems and involve in research activities.
2. Able to Plan, design and execute the societal applications of Civil engineering.
3. To Involve effectively as a member or as a leader towards achieving goals in Civil engineering projects.
4. To Engage in professional consultancy and continuous learning to accomplish professional growth.

## Program Outcomes (PO's)

The graduates of the Civil Engineering Department will have the ability of

1. **Engineering knowledge:** Apply the knowledge of mathematics, science, engineering fundamentals, and an engineering specialization to the solution of complex engineering problems.
2. **Problem analysis:** Identify, formulate, research literature, and analyze complex engineering problems reaching substantiated conclusions using first principles of mathematics, natural sciences, and engineering sciences.
3. **Design/development of solutions:** Design solutions for complex engineering problems and design system components or processes that meet the specified needs with appropriate consideration for the public health and safety, and the cultural, societal, and environmental considerations.
4. **Conduct investigations of complex problems:** Use research-based knowledge and research methods including design of experiments, analysis and interpretation of data, and synthesis of the information to provide valid conclusions.
5. **Modern tool usage:** Create, select, and apply appropriate techniques, resources, and modern engineering and IT tools including prediction and modelling to complex engineering activities with an understanding of the limitations
6. **The engineer and society:** Apply reasoning informed by the contextual knowledge to assess societal, health, safety, legal and cultural issues and the consequent responsibilities relevant to the professional engineering practice.
7. **Environment and sustainability:** Understand the impact of the professional engineering solutions in societal and environmental contexts, and demonstrate the knowledge of, and need for sustainable development.
8. **Ethics:** Apply ethical principles and commit to professional ethics and responsibilities and norms of the engineering practice.
9. **Individual and team work:** Function effectively as an individual, and as a member or leader in diverse teams, and in multidisciplinary settings.
10. **Communication:** Communicate effectively on complex engineering activities with the engineering community and with society at large, such as, being able to comprehend and write effective reports and design documentation, make effective presentations, and give and receive clear instructions.

11. **Project management and finance:** Demonstrate knowledge and understanding of the engineering and management principles and apply these to one's own work, as a member and leader in a team, to manage projects and in multidisciplinary environments.
12. **Life-long learning:** Recognize the need for, and have the preparation and ability to engage in independent and life-long learning in the broadest context of technological change

### **Program Specific Outcomes (PSO's)**

By the completion of Civil engineering program, graduates are able to

1. Utilize the Civil engineering knowledge and problem analysis skills to conceptualize, develop, and execute the civil engineering projects.
2. Deploying quality Civil Engineers to work towards societal needs to achieve environmental and sustainable development

## COMPUTER AIDED DEATILING OF STRUCTURES

**Course Code: 15CVL77**

**Exam Hours: 03**

**Exam Marks: 80**

**IA Marks: 20**

**Totals Hrs: 40**

**Hrs/ Week: 03(1I+2D)**

**Credits-02**

### List of Exercises

Modules	Teaching Hours	Revised Bloom's Taxonomy (RBT) Level
<b>Module -1 Detailing of RCC Structures</b>		
1. Beams – Simply supported, Cantilever and Continuous. 2. Slab – One way, Two way and One-way continuous. 3. Staircase – Doglegged 4. Cantilever Retaining Wall 5. Counter fort Retaining wall 6. Circular water tank, Rectangular water tank	20 hours	L1, L2, L3
<b>Module -2 Detailing of Steel Structures</b>		
1. Connections – Beam to beam, Beam to Column by Bolted and Welded Connections. 2. Built-up Columns with lacings and battens 3. Column bases and Gusseted bases with bolted and welded connections. 4. Roof Truss – Welded and Bolted 5. Beams with Bolted and Welded 6. Gantry Girder	20 hours	L1, L2, L3

**Course objectives:** This course will enable students to

1. Be aware of the Scale Factors, Sections of drawings,
2. Draft the detailing of RC and Steel Structural member.

#### **Pre-requisite**

Basic knowledge of Engineering Drawing, Projections, Design of RCC Structural Elements, Design of Steel Structures.

**Course Outcomes (COs)** after studying this course, students will be able to

**CO1-** Create the structural drawings of different components of the buildings.

**CO2-** Prepare the Structural drawings of Retaining wall & Water tank.

**CO3-** Interpret the design data to draw connection details, built up sections and column bases.

**CO4-** Create the Structural drawings of roof truss & girder

## MODULE-1-- Detailing of RCC Structures

### Exercise-01 Detailing of Simply Supported Beam

1. Draw the Longitudinal section, cross section of a rectangular simply supported RCC beam with the following data:  
 Clear span = 4.5m  
 Width of beam = 250mm  
 Overall depth of beam = 300mm  
 Main reinforcement = 5 Nos -18 mm diameter bars with 2 bars bent up at 900mm from inside of each end support  
 Anchor/hanger bars = 2-12 mm diameter  
 Stirrups = 6 mm diameter @ 200 mm c/c.  
 Concrete cover = 25 mm  
 Materials : HYSD bars, M20 grade concrete.

#### i) Longitudinal and Cross-Section:

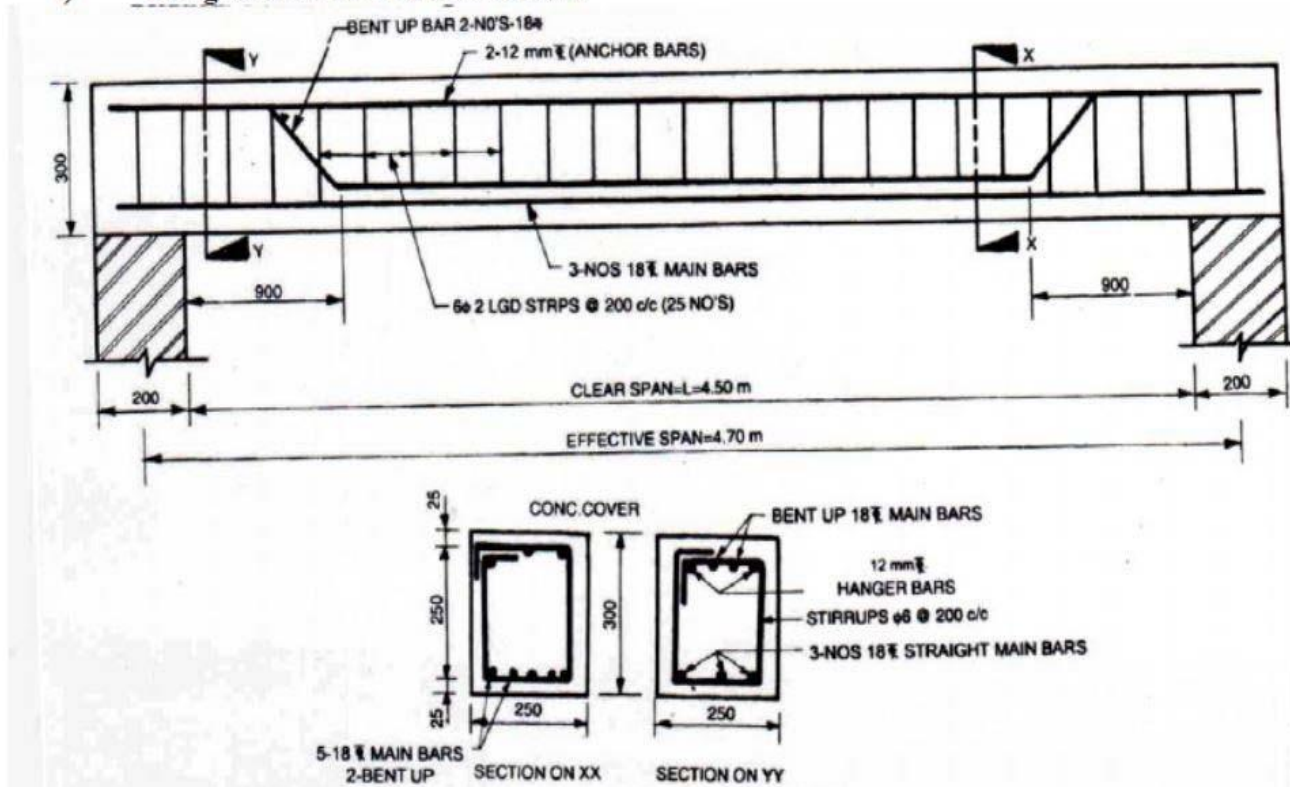

## Exercise-02 Detailing of Simply Supported Beam

2. Draw the longitudinal section and cross section of a rectangular RCC beam simply supported with the following data:  
 Clear span = 4.8m  
 Bearing at the supports = 300mm  
 Width of beam = 300mm  
 Overall depth of beam = 500mm  
 Main reinforcement consists of #5 - 20 $\phi$  bars in two layers  
 Provide #2 - 12 $\phi$  as anchor bars.  
 Stirrups: 2L 8 $\phi$  @ 180 c/c near the supports up to 1.20m and @ 220 c/c in the remaining portion.

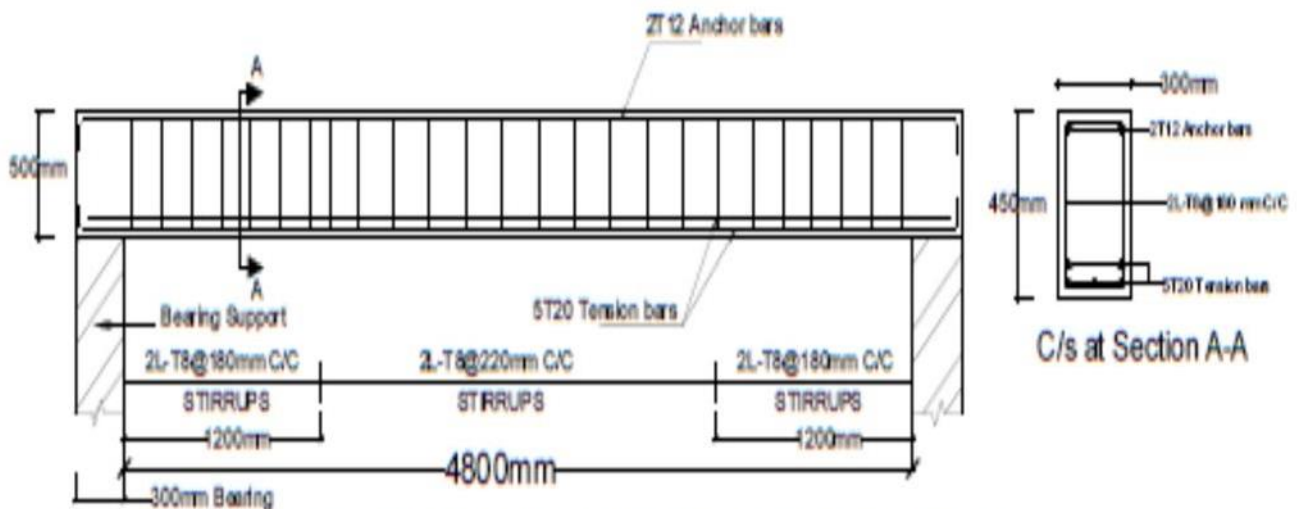

**L/S OF SIMPLY SUPPORTED SINGLY REINFORCED BEAM**

### Exercise-03 Detailing of Doubly reinforced Rectangular Beam

1. Draw a detailed longitudinal section, a cross section near the supports and a section at the middle of the span of a simply supported doubly reinforced beam for the following data:

Clear span = 5.4m

Bearing over the supports = 300mm

Size = 300 x 800 mm

Main reinforcement tensile: #7 - 25 $\phi$ . 4 straight and 3 bent up @ 1400mm from support.

Compression reinforcement: #4 - 2 $\phi$

Spacer bars=25  $\phi$

Side face reinforcement=#2-12 $\phi$

Shear reinforcement: 2L - 12 $\phi$  @ 150 c/c for a distance of 1.5m from the support and 2L - 12 $\phi$  @ 300 c/c for remaining middle portion.

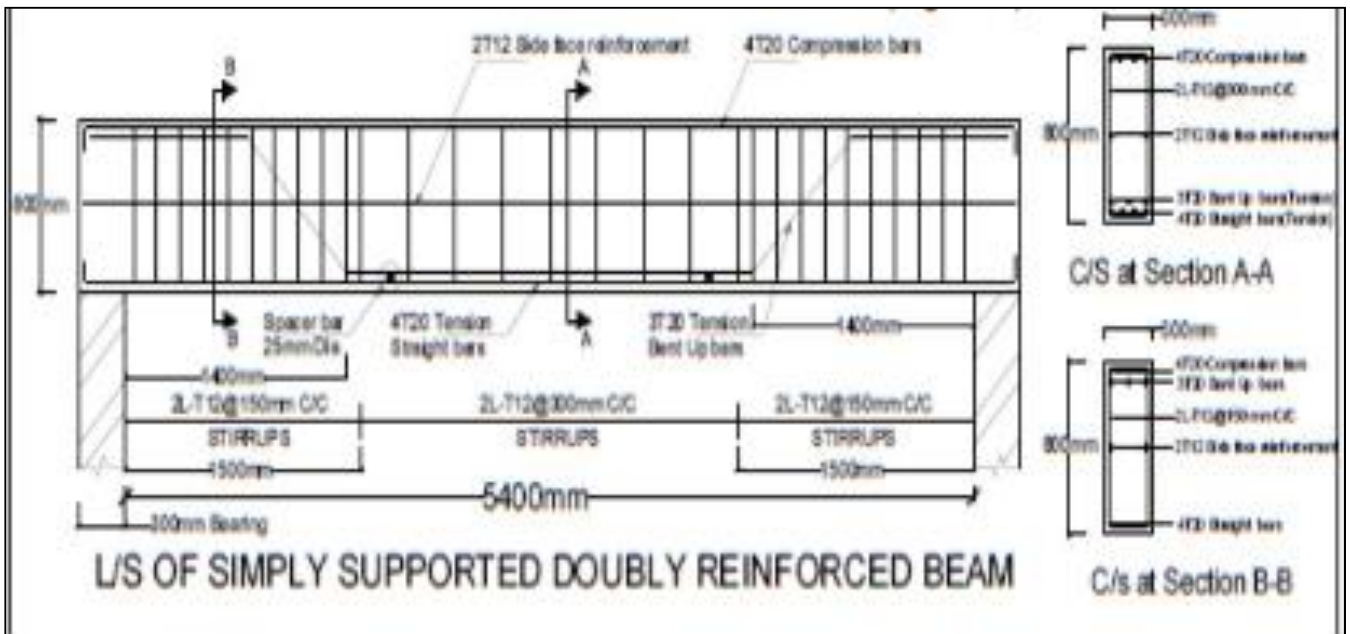



### Exercise-04 Detailing of Continuous Rectangular Beam

1. Draw the Longitudinal section and two cross sections one near the support and other near the mid span of a RCC continuous beam with the following data:  
 Clear span of beams = 3m each  
 Width of beam = 200mm  
 Overall depth of beam = 300mm  
 Width in intermediate supports = 200 mm  
 Main reinforcement = 4 Nos -12 mm diameter bars with 2 bars bent up  
 Anchor/hanger bars= 2-10 mm diameter  
 Stirrups = 6 mm diameter @ 300 mm c/c.  
 Materials : HYSD bars and M20 grade concrete

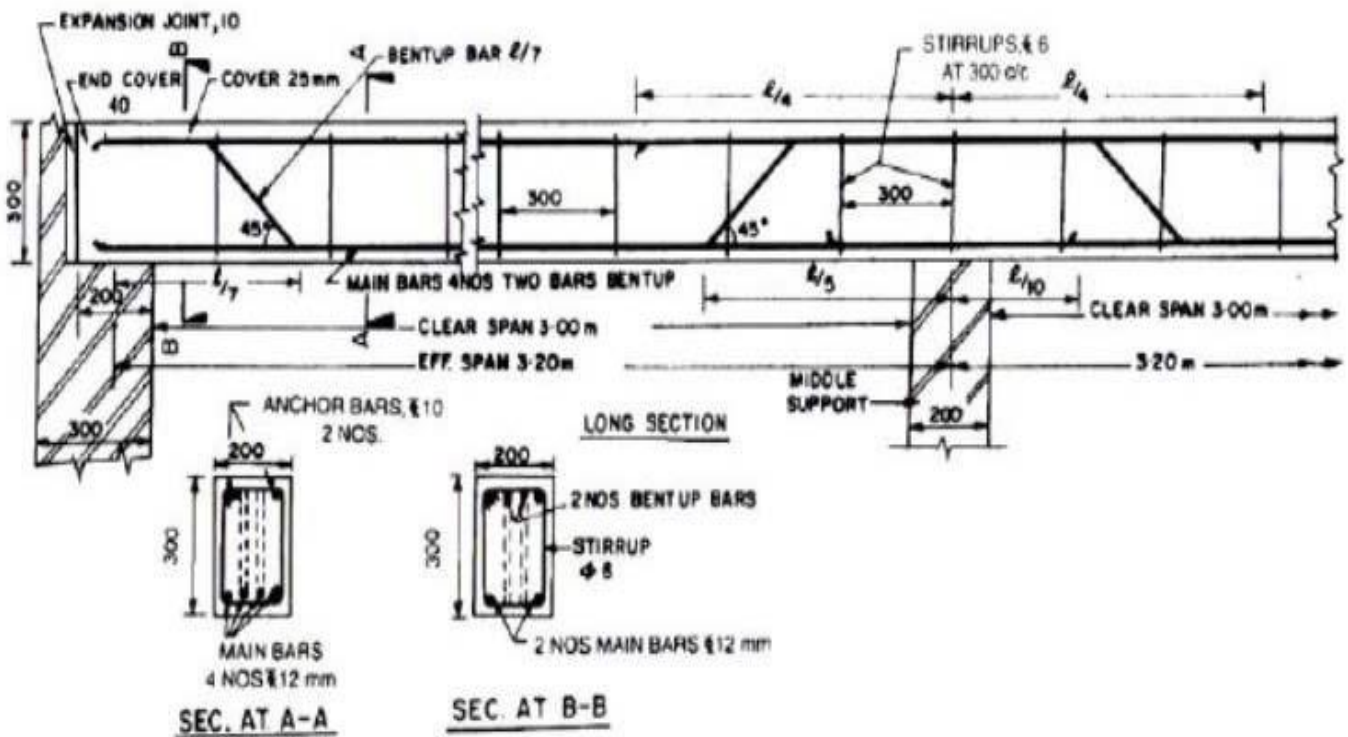

### Exercise-05 Detailing of Cantilever Beam

1. Draw to a suitable scale the Longitudinal section and two cross-section of a cantilever beam projecting 3.2 from a support using following data  
 Clear span = 3.2m  
 Overall depth at free end = 150 mm  
 Overall depth at fixed end = 450 mm  
 Width of cantilever beam = 300 mm  
 Main steel = 4-28 mm dia with two bars curtailed at 1.5m from support  
 Anchor bars = 2 Nos. 16 mm dia  
 Nominal stirrups = 6mm dia at 40 mm c/c  
 Bearing at fixed end = 300 mm  
 Use M20 concrete and Fe 415 steel.

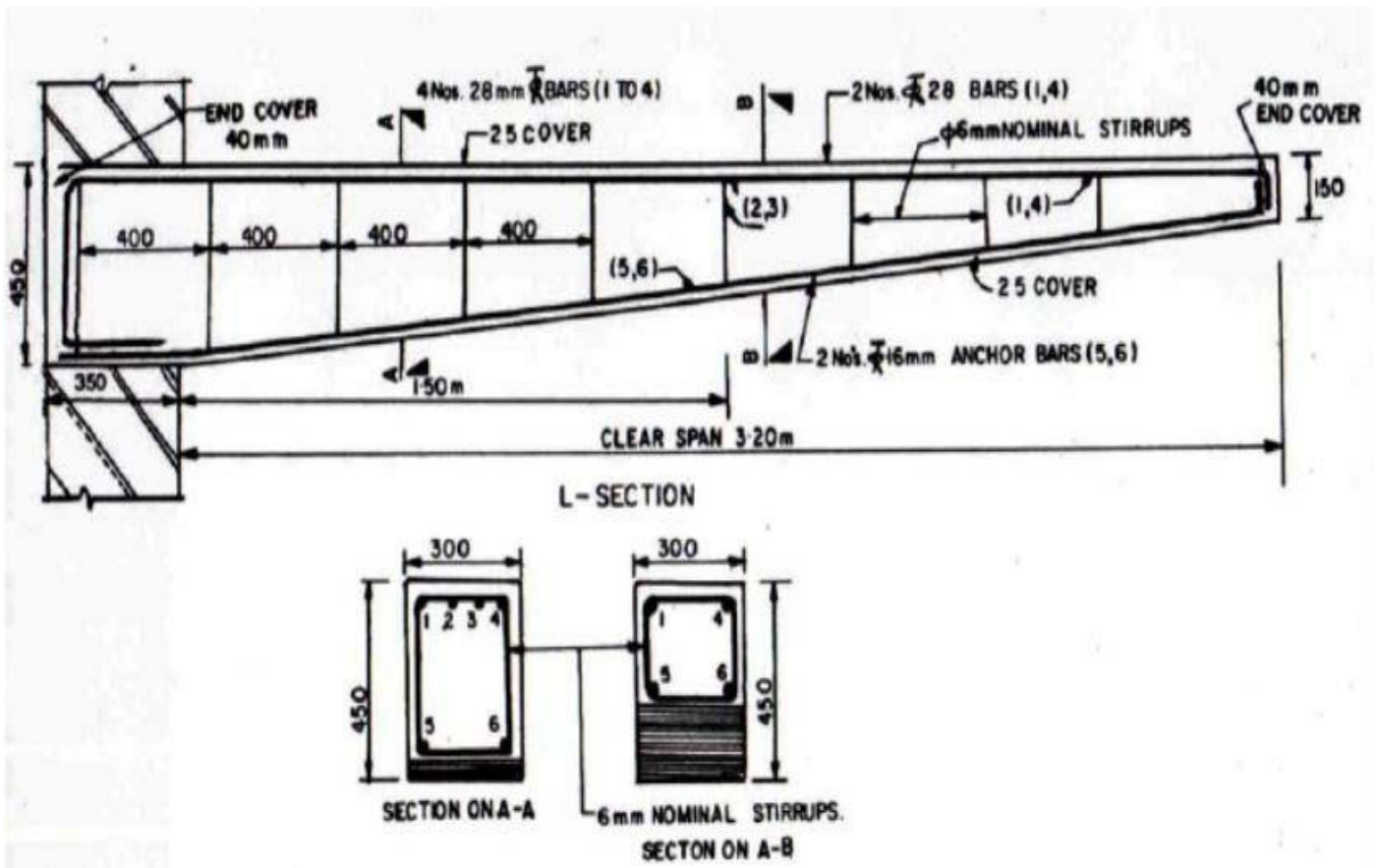

### Exercise-06 Detailing of Cantilever Beam

2. Draw longitudinal section and cross section of a cantilever beam from the following data:

Clear projection from the face of RCC column = 2500mm

Size of column = 300mm x 300mm

Size of beam at fixed end = 300mm x 300mm

Size of beam at free end = 300mm x 150mm

Reinforcement main bars: #5 - 20 $\phi$  with 2 bars curtailed at 1500mm from the support and show the curtailment plan.

Compression bars: #3 - 16 $\phi$

Stirrups: 2L - 6 $\phi$  @ 200 c/c up to 1000mm from support and @ 300 c/c in remaining length.

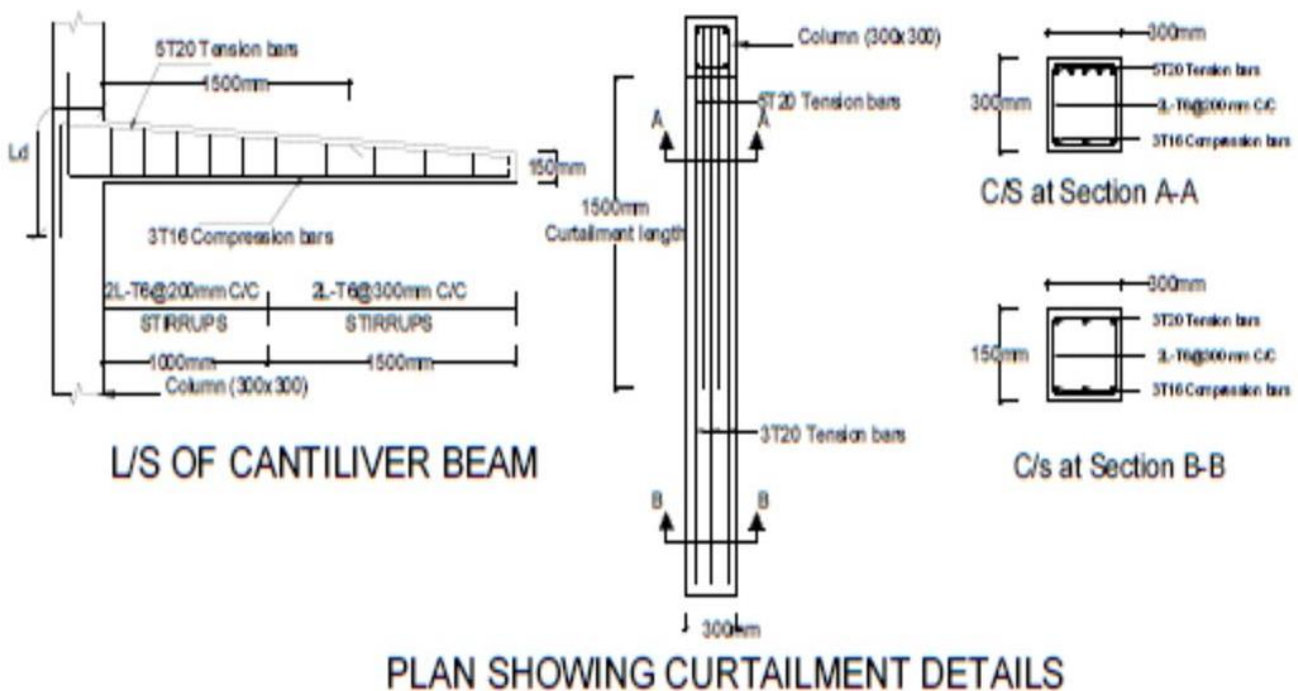

### Exercise-07 Detailing of One Way Slab

1. Draw cross section and plan of one way roof slab showing the details of reinforcement for the following data:  
 Clear span = 4m  
 Length of slab = 10m  
 Thickness of slab = 130mm  
 Bearing wall = 200mm  
 Main reinforcement:  $12\phi @ 250$  c/c with alternate bars bent up.  
 Distribution reinforcement:  $8\phi @ 200$  c/c.

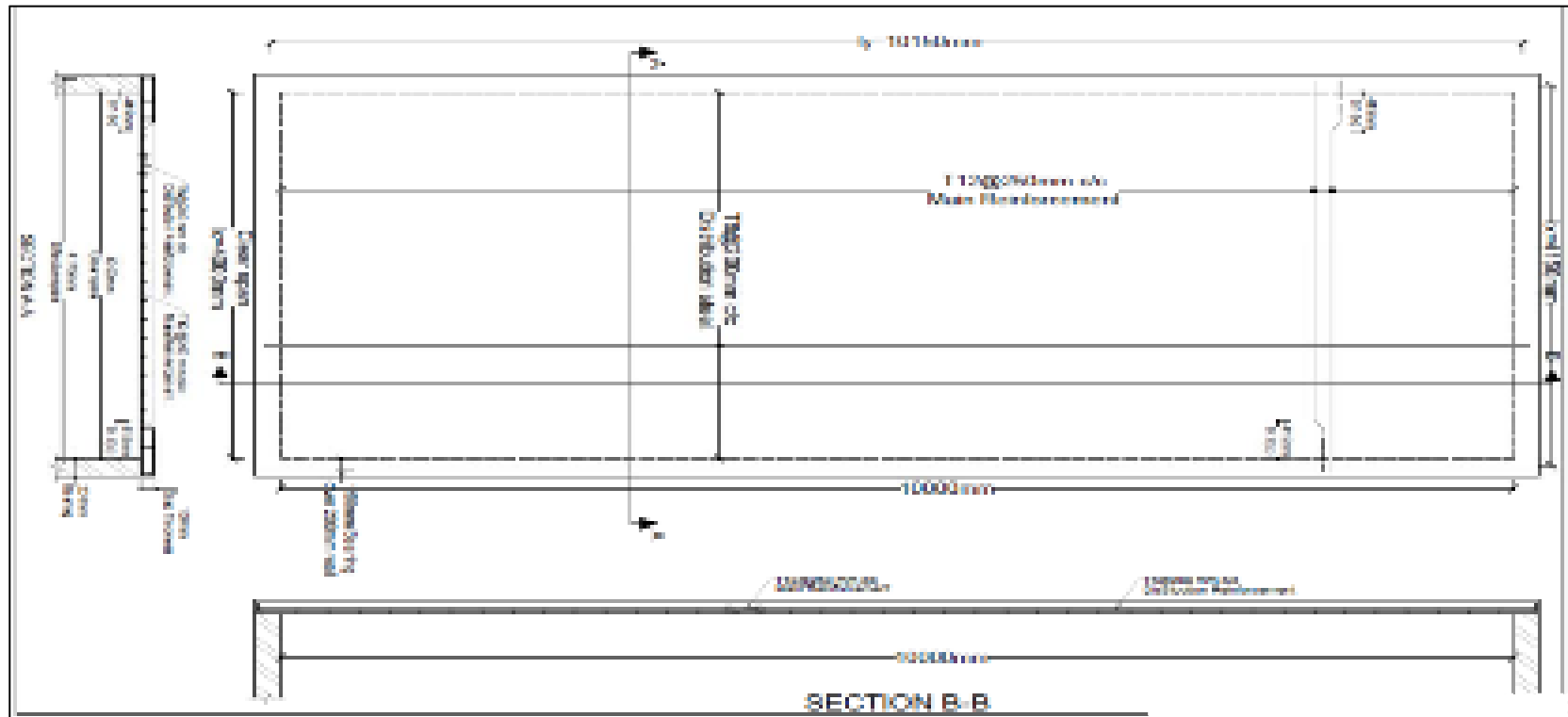

### Exercise-08 Detailing of Two Way Slab

- A simply supported two way slab is supported on all sides by using 230mm thick wall. The dimension of two-way slab is 3m x 4m (Clear). Following are the reinforcement details:  
 Along shorter span:  $10\phi @125$  c/c. Along longer span:  $10\phi @150$  c/c.  
 Negative steel for shorter span:  $10\phi @250$  c/c. Negative steel for longer span:  $10\phi @300$  c/c.  
 Alternative bars are cranked. Corner mats are  $8\phi @150$  c/c along shorter span and  $8\phi @200$  c/c along long span.  
 Thickness of slab is 150mm. Draw plan showing reinforcement and cross section along longer & shorter span.

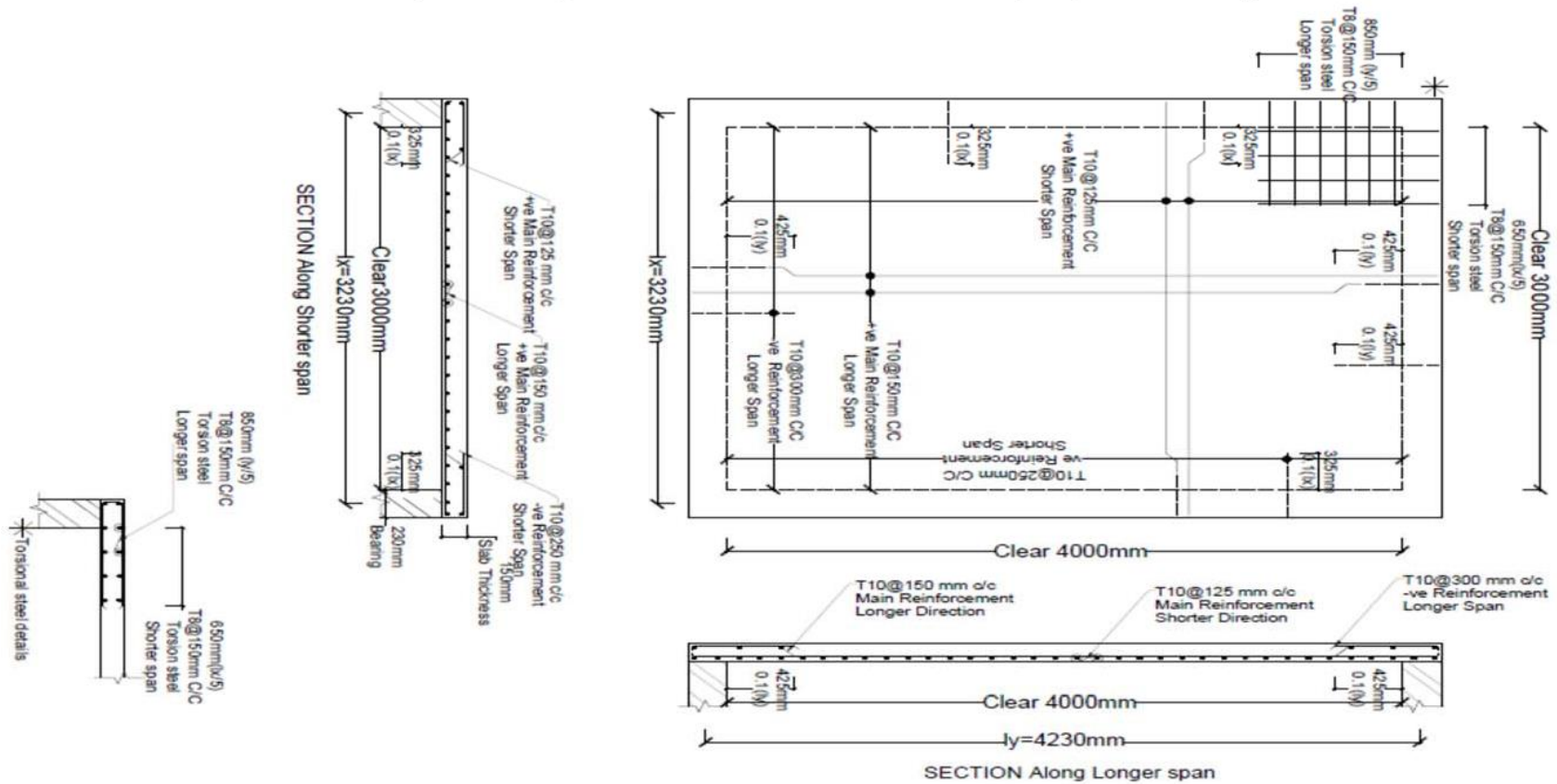

**Exercise-09**  
**Detailing of Dog legged Staircase**

1. A dog legged stair case has to be provided for a residential building with the staircase room size 2.1 m x 4.48 m (internal). The following details are given:  
 Vertical distance between the floors = 3.2 m  
 Waist slab thickness = 160 mm  
 Wall thickness = 230 mm  
 Main reinforcement = 12 mm dia @ 120 mm c/c  
 Distribution steel = 8 mm dia @ 200 mm c/c  
 Grade of concrete used = M20  
 Grade of steel used = Fe415  
 First flight starts from foundation level.

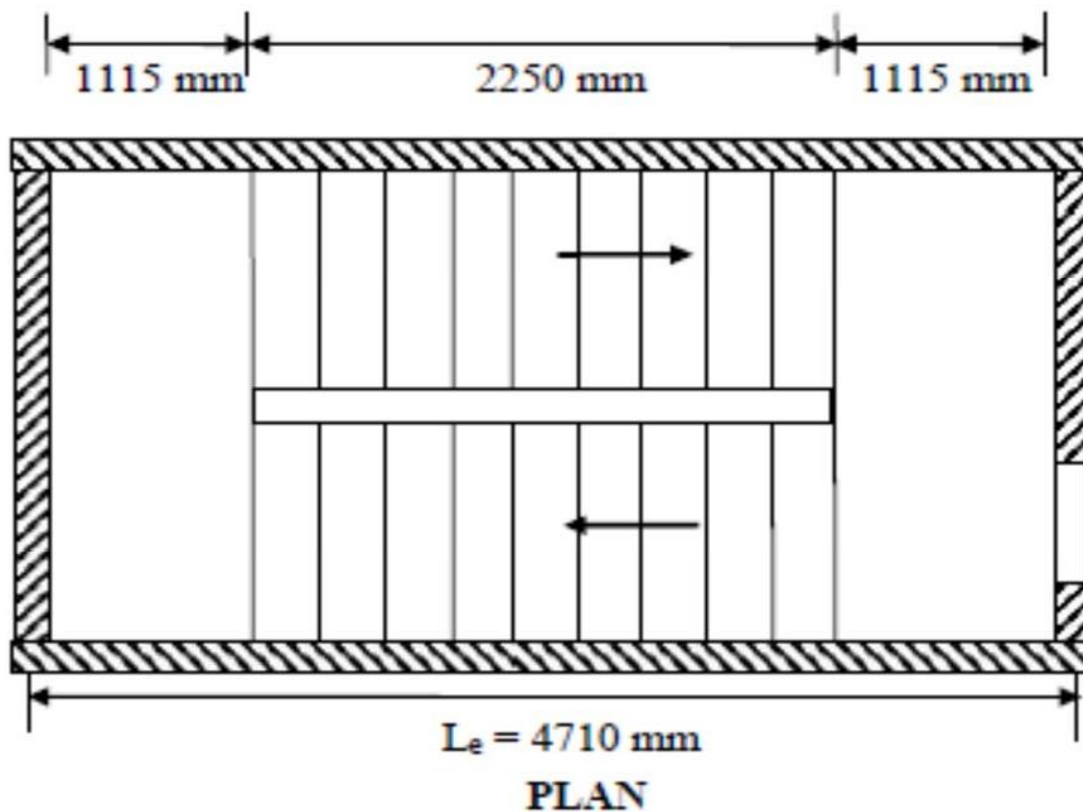

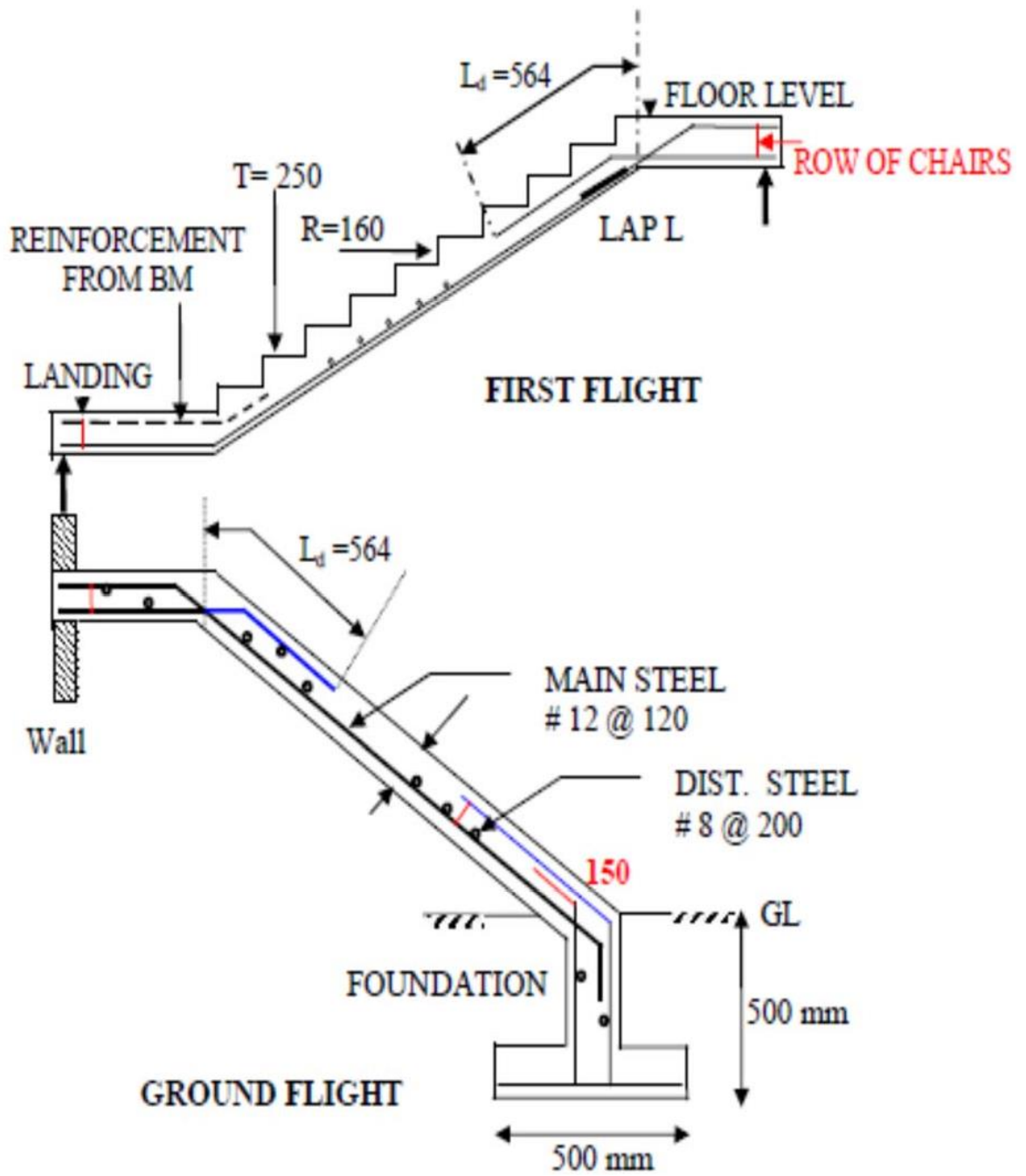

### Exercise-10 Detailing of Cantilever Retaining wall

1. Draw the Sectional elevation, longitudinal section and sectional plan of a cantilever retaining wall for the following data:

Total height of retaining wall = 5.2 m; Thickness of base slab = 0.55 m;

Width of base slab = 3m; Width of heel slab = 1.75 m; Top width of stem = 200mm;

Bottom width of stem = 550mm;

**Stem reinforcement:** 12mm dia @ 120mm C/C at bottom  $h/2$  and 240mm C/C at top  $h/2$ ,  
Distribution steel 8mm dia @ 150mm C/C on either side.

**Heel slab reinforcement:** Main steel of 12 dia @ 150 mm C/C and distribution steel of 8 mm dia @ 150 mm C/C.

**Toe slab reinforcement:** Main steel and distribution steel of 10 mm dia @ 120 mm C/C.  
Depth of Shear key = 0.5m.

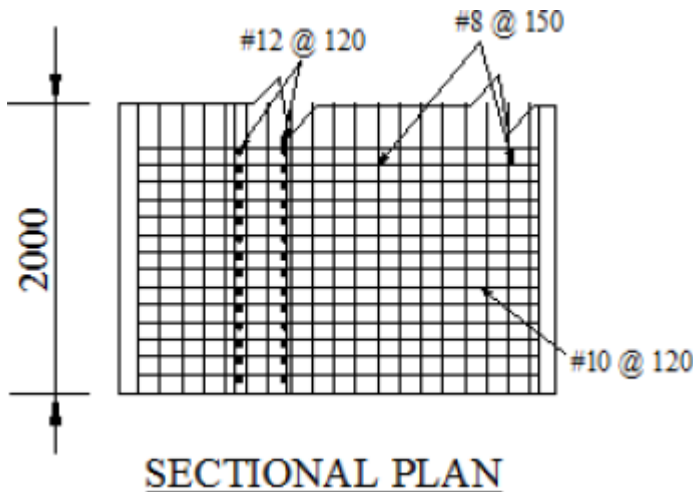
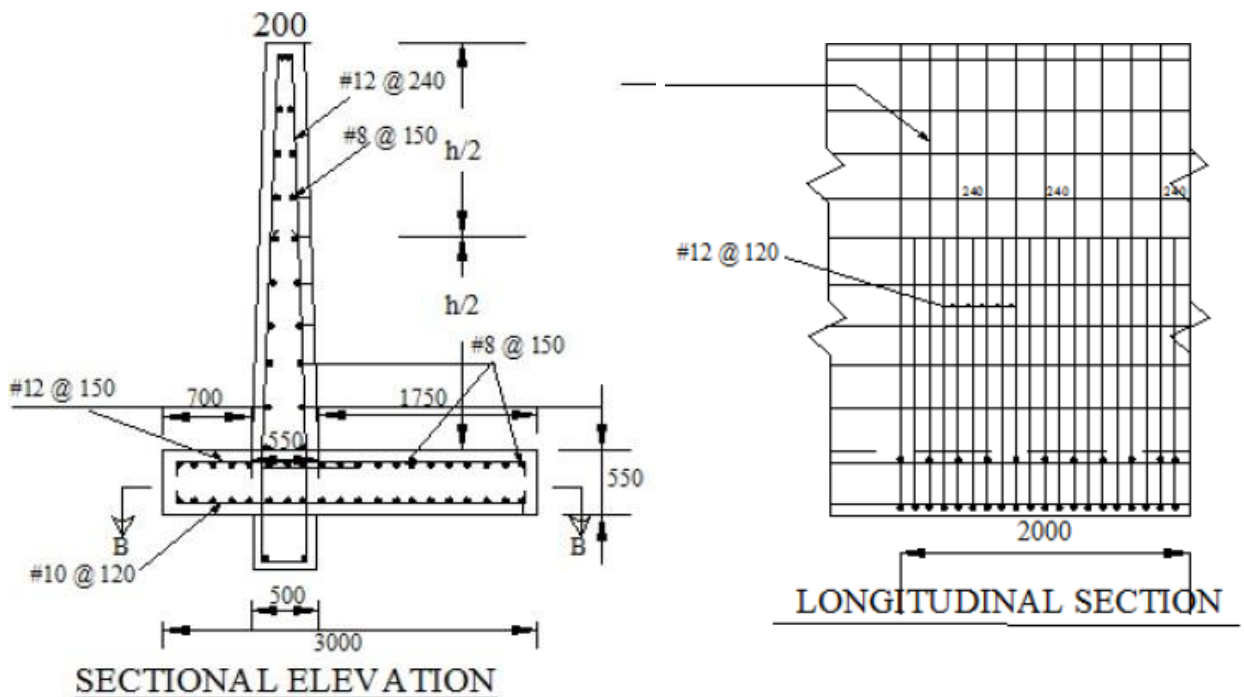



### Exercise-11 Detailing of Counterfort Retaining wall

1. Draw the midspan cross section, cross section through counterfort and sectional plan of a counterfort retaining wall for the following data:

Total height of retaining wall = 7.2 m; Height above ground level = 6 m; Spacing of counterfort = 3m C/C; Thickness of base slab = 0.45 m; Width of base slab = 4.8 m; Width of heel slab = 3.35 m; width of stem = 250mm;

**Stem reinforcement:** 12mm dia @ 180mm C/C at bottom h/2 and 360mm C/C at top h/2, Distribution steel 8mm dia @ 300mm C/C on either side.

**Heel slab reinforcement:** Main steel of 10 dia @ 150 mm C/C and distribution steel of 8 mm dia @ 200 mm C/C.

**Toe slab reinforcement:** Main steel 12 dia @ 140 mm C/C and distribution steel of 10 mm dia @ 240 mm C/C.

**Counterfort reinforcement:** 8# 25 mm dia; Curtailment of main bars 2 are cut off at 5.85m from top, 4 are cut off at 4.8 from top and 6 are cut off at 3.4 from top.

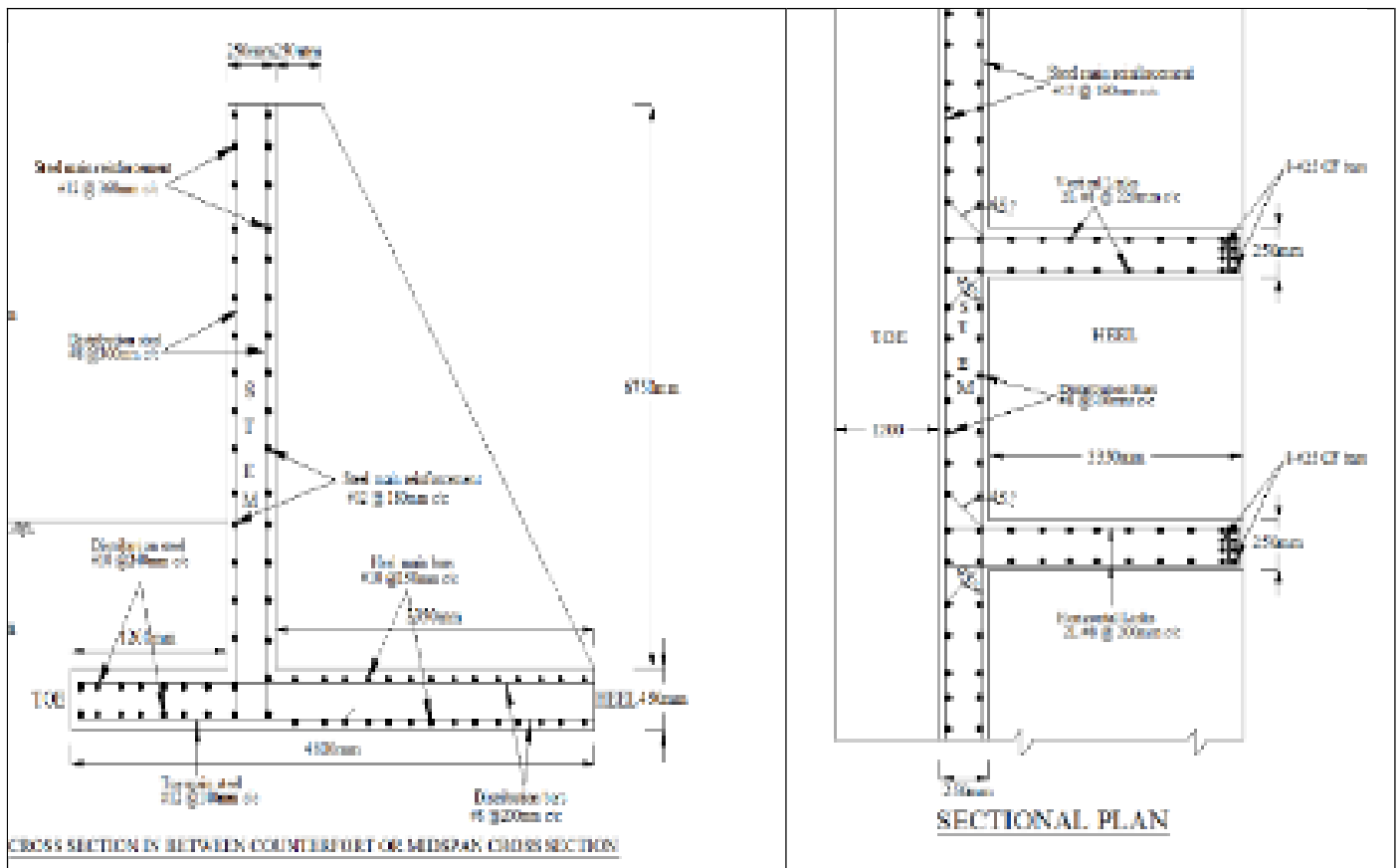

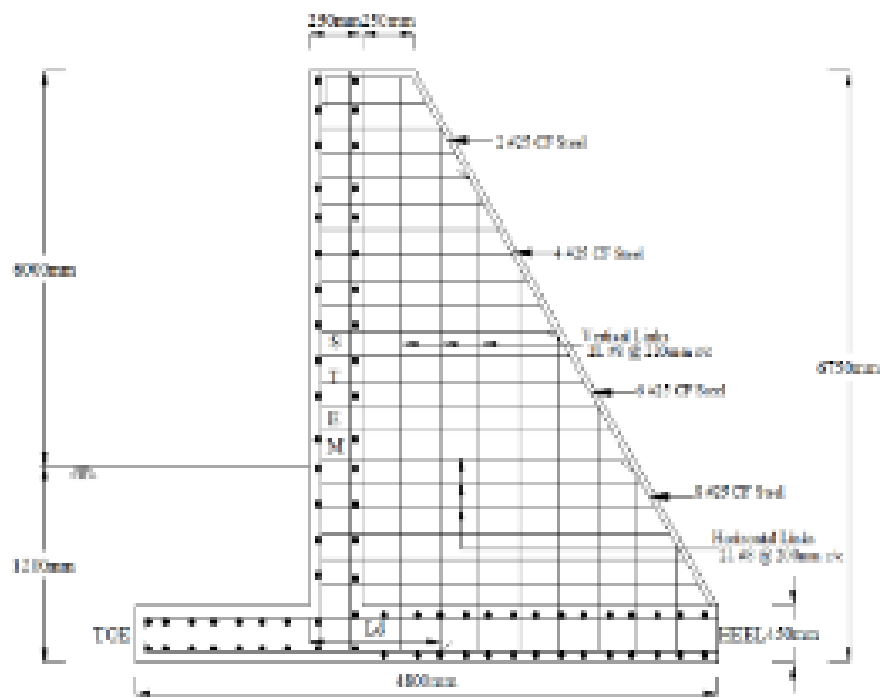

CROSS SECTION THROUGH THE COUNTERFOOT

### Exercise-12 Detailing of Rectangular water Tank

1. Draw the Longitudinal section and sectional plan of the rectangular water tank for the following details:

Size of tank = 6mX2m

**Reinforcement of long wall:**

Horizontal steel - 12 dia @ 150 C/C; Vertical steel - 16 dia @ 200 C/C.

**Reinforcement of short wall:**

Horizontal steel and Vertical steel both are 12 dia @ 180 C/C.

Base slab of 200 mm thick with 10 dia @ 250 mm C/C on either direction.

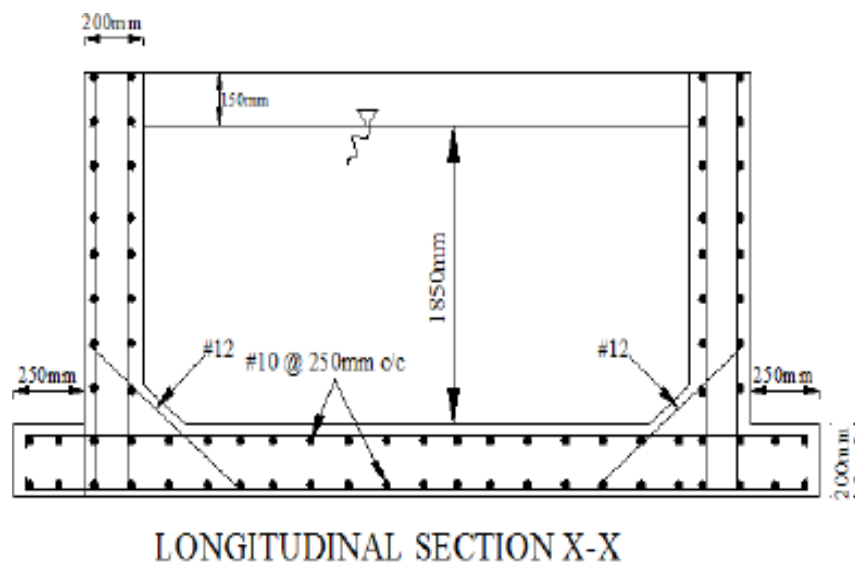
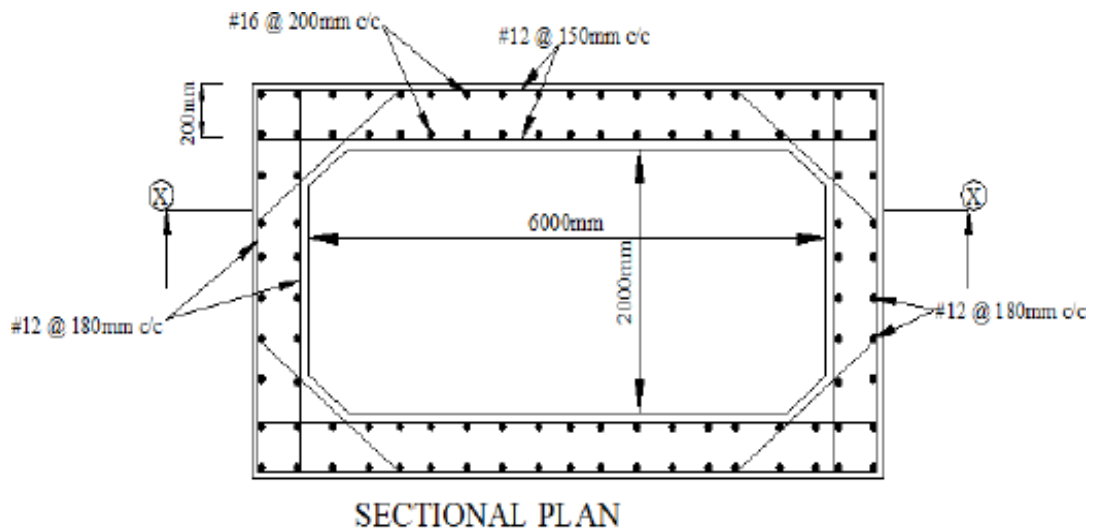

## MODULE-2-- Detailing of Steel Structures

### Exercise-01

#### Beam-Beam Framed Connection: (Bolted)

1. Two secondary beams ISLB-300 @ 37.7kg/m and ISMB-500 are connected to main beam ISMB-600.

Size of cleat angle ISA 90x90x8 mm.

Use bolted connection.

Provide 3-#20 bolts for angle and ISLB-300

4-#20 bolts for angle and ISMB-500

3-#20 bolts per cleat angle for main beam connection.

Use pitch (p) =60mm

Edge distance (e) =35mm

Draw- Front View

Side View

Sectional Plan

#### **Solution:**

#### **Data:**

	h	b	tf	tw
ISLB-300	300	150	9.4	6.7
ISMB-500	500	180	17.2	10.2
ISMB-600	600	210	20.8	12
Cleat Angle	90*90*8			

### Exercise-02

#### Beam-Beam Framed Connection: (Welded)

1. Two secondary beams ISLB-300 @ 37.7kg/m and ISMB-500 are connected to main beam ISMB-600.

Size of cleat angle ISA 90x90x8 mm.

Use Welded connection.

Draw- Front View

Side View

Sectional Plan

#### **Solution:**

#### **Data:**

	h	b	tf	tw
ISLB-300	300	150	9.4	6.7
ISMB-500	500	180	17.2	10.2
ISMB-600	600	210	20.8	12
Cleat Angle	90*90*8			

**Exercise-03****Beam-Column Framed Connection: (Welded)**

1. A beam ISMB-400 @ 61.6 kg/m is connected to flange of a column ISHB-400 @ 82.2 kg/m using welded connection.

Size of cleat angle ISA 150x115x12 mm.

Draw- Front View

Side View

Sectional Plan

**Solution:****Data:**

	h	b	tf	tw
ISHB-400	400	250	12.7	10.6
ISMB-400	400	140	16	8.9
Cleat Angle	150*115*12			

**Exercise-04****Beam-Column Framed Connection: (bolted)**

1. A beam ISMB-400 @ 61.6 kg/m is connected to flange of a column ISHB-400 @ 82.2 kg/m using bolted connection.

Size of cleat angle ISA 150x115x12 mm.

6-#20mm bolt in two rows is used to connect angle and beam.

3-#20mm bolt for each angle to connect angle and column flange.

Use- pitch=60mm, edge distance=35mm

Draw- Front View

Side View

Sectional Plan

**Solution:****Data:**

	h	b	tf	tw
ISHB-400	400	250	12.7	10.6
ISMB-400	400	140	16	8.9
Cleat Angle	150*115*12			

**Exercise-05****Beam-Column Unstiffened Seat Connection: (Welded)**

1. A beam ISMB-400 @ 61.6 kg/m is connected to web of a column ISHB-400 @ 82.2 kg/m using welded connection.

Size of cleat angle ISA 90\*90\*8 mm.

Size of seat angle ISA 150\*115\*15 mm.

Draw- Front View

Side View

Sectional Plan

**Solution:**

Beam is connected to 'web' of a column

**Data:**

	h	b	tf	tw
ISHB-400 @82.2 kg/m	400	250	12.7	10.6
ISMB-400 @ 61.6 kg/m	400	140	16	8.9
Cleat Angle	90*90*8			
Seat Angle	150*115*15			

**Exercise-06****Beam-Column Unstiffened Seat Connection: (bolted)**

1. A beam ISMB-400 @ 61.6 kg/m is connected to web of a column ISHB-400 @ 82.2 kg/m using bolted connection.

Size of cleat angle ISA 90x90x8 mm.

Size of seat angle ISA 150x115x15 mm.

4-#22mm bolts for seat angle with column web

2-#20mm for remaining connections.

Draw- Front View

Side View

Sectional Plan

**Solution:**

Beam is connected to 'web' of a column

**Data:**

	h	b	tf	tw
ISHB-400 @82.2 kg/m	400	250	12.7	10.6
ISMB-400 @ 61.6 kg/m	400	140	16	8.9
Cleat Angle	90*90*8			
Seat Angle	150*115*15			

**Exercise-07****Beam-Column Unstiffened Seat Connection: (Welded)**

1. A beam ISMB-400 @ 61.6 kg/m is connected to flange of a column ISHB-400 @ 82.2 kg/m using welded connection.

Size of cleat angle ISA 90x90x8 mm.

Size of seat angle ISA 100x100x10 mm.

Pair of stiffener- 2 ISA 90x90x8mm, 500mm length.

Draw- Front View

Side View

Sectional Plan

**Solution:**

Beam is connected to 'flange' of a column

**Data:**

	h	b	tf	tw
ISHB-400 @82.2 kg/m	400	250	12.7	10.6
ISMB-400 @ 61.6 kg/m	400	140	16	8.9
Cleat Angle	90*90*8			
Seat Angle	100*100*10			
Stiffener Angle (2 no.)	90*90*8			

**Exercise-08****Beam-Column Unstiffened Seat Connection: (bolted)**

1. A beam ISMB-400 @ 61.6 kg/m is connected to flange of a column ISHB-400 @ 82.2 kg/m using bolted connection.

Size of cleat angle ISA 90x90x8 mm.

Size of seat angle ISA 100x100x10 mm.

Pair of stiffener- 2 ISA 90x90x8mm, 500mm length.

8-#20mm bolts for stiffener to column in two rows

2-#20mm for remaining connection.

Draw- Front View

Side View

Sectional Plan

**Solution:**

Beam is connected to 'flange' of a column

**Data:**

	h	b	tf	tw
ISHB-400 @82.2 kg/m	400	250	12.7	10.6
ISMB-400 @ 61.6 kg/m	400	140	16	8.9
Cleat Angle	90*90*8			
Seat Angle	100*100*10			
Stiffener Angle (2 no.)	90*90*8			

Exercise-01

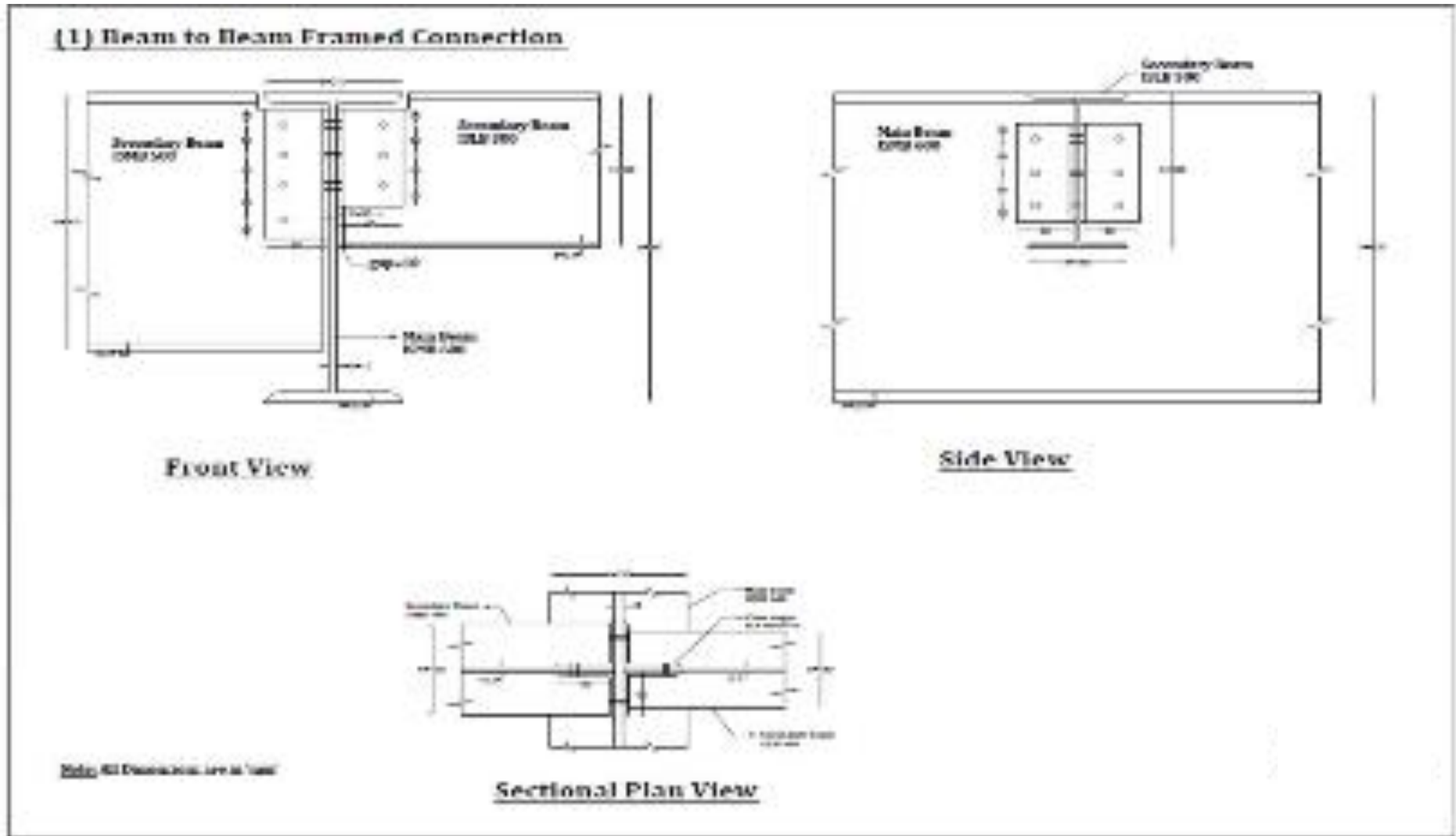



Exercise-02

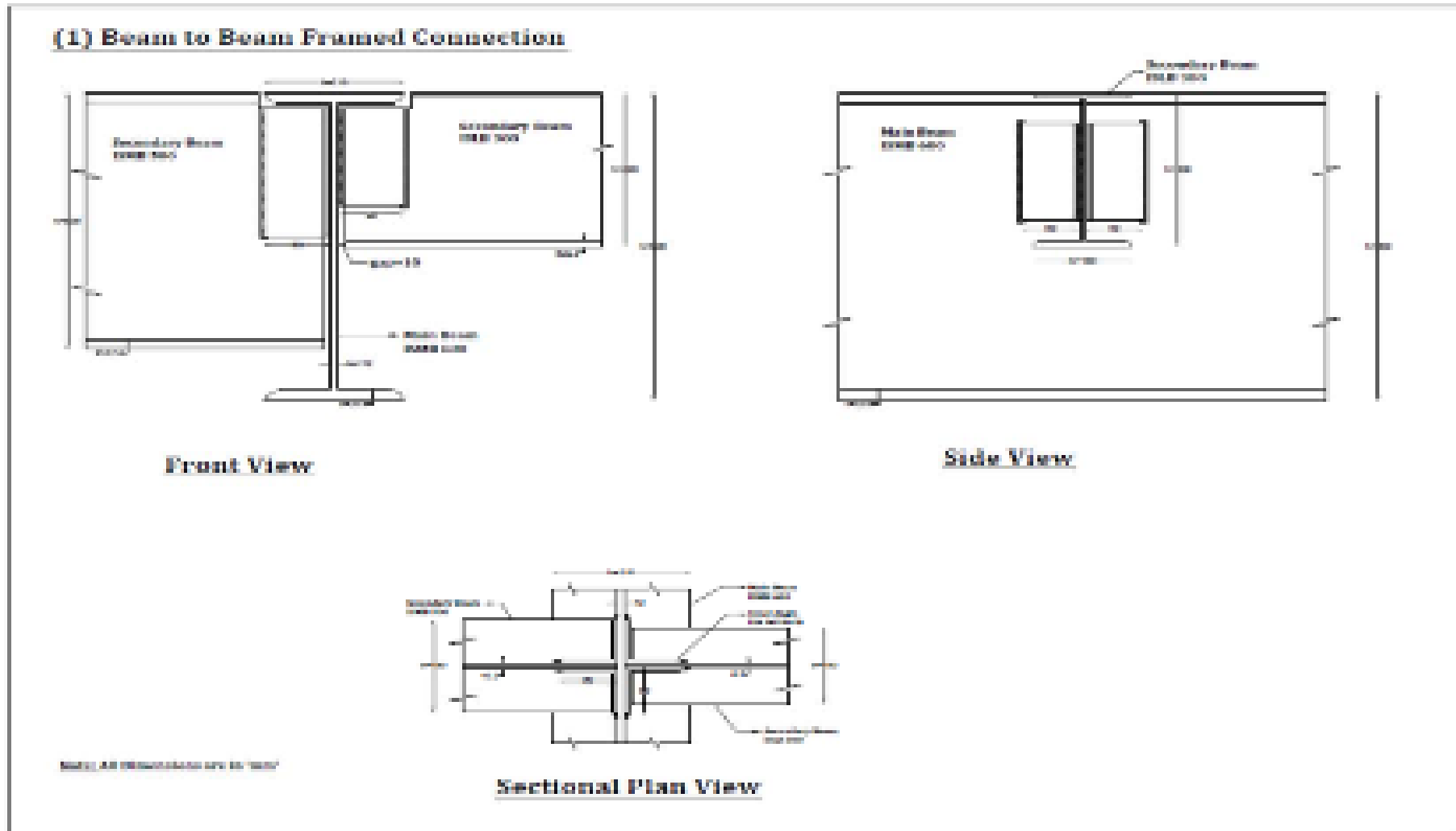

Exercise-03

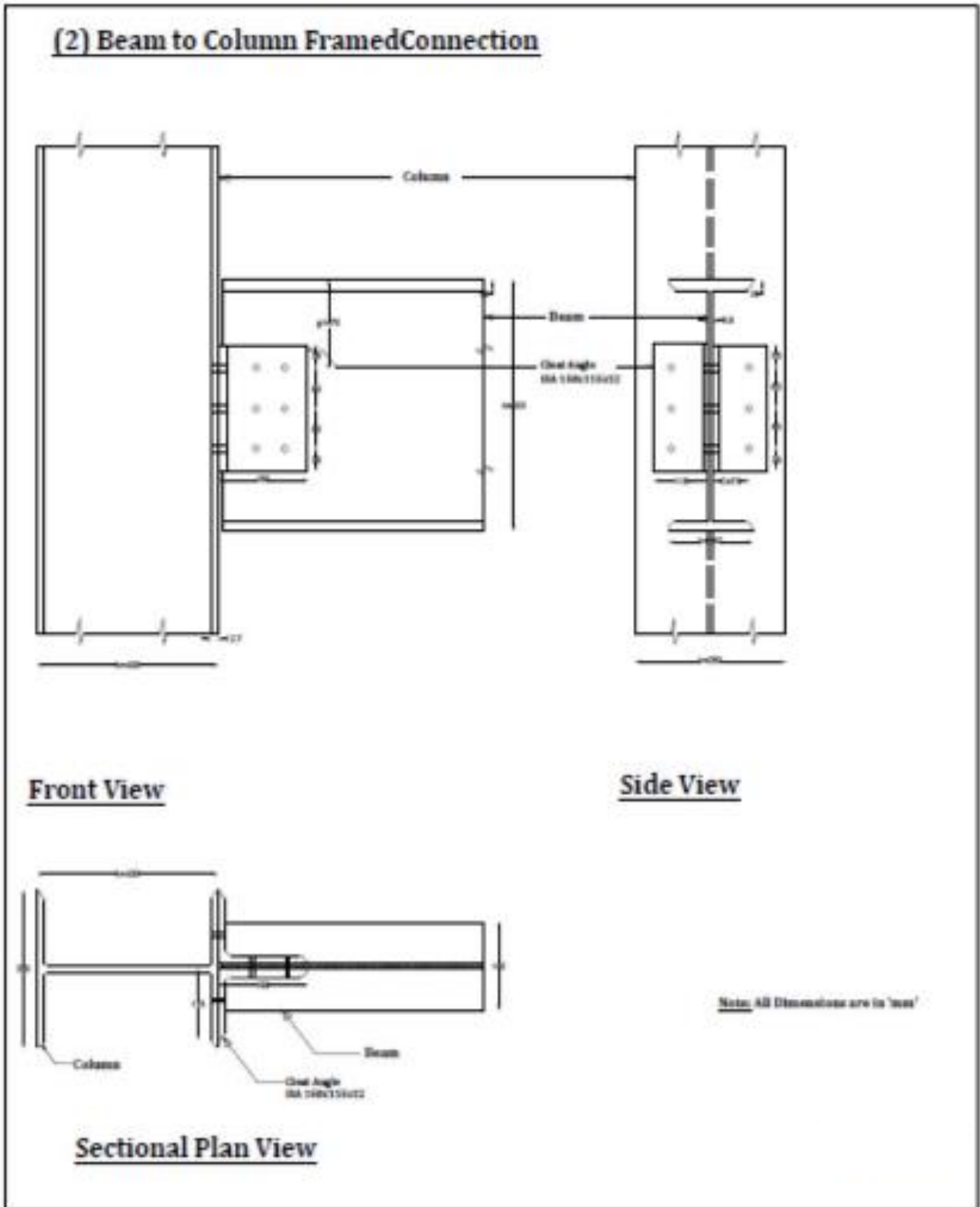

Exercise-04

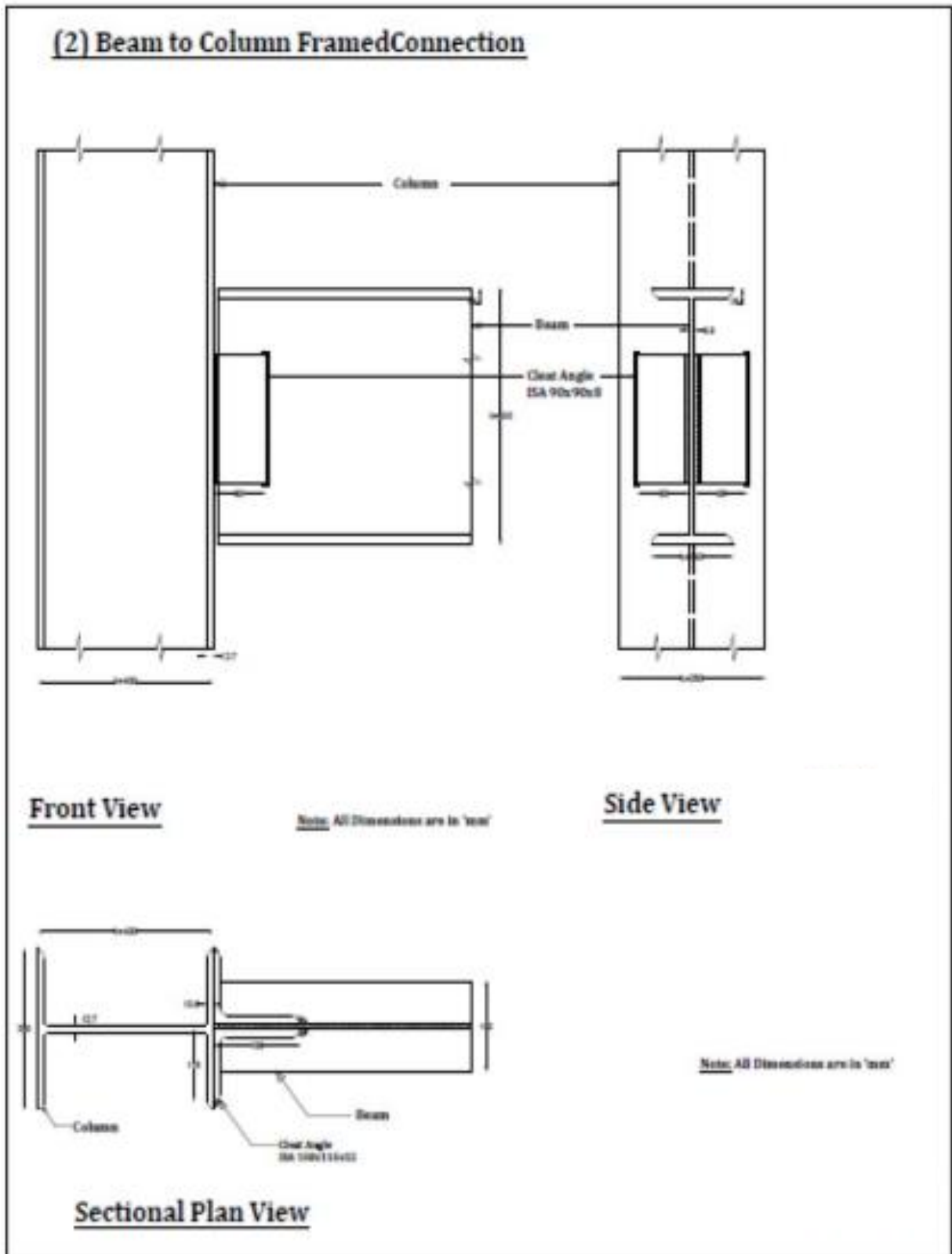

Exercise-05

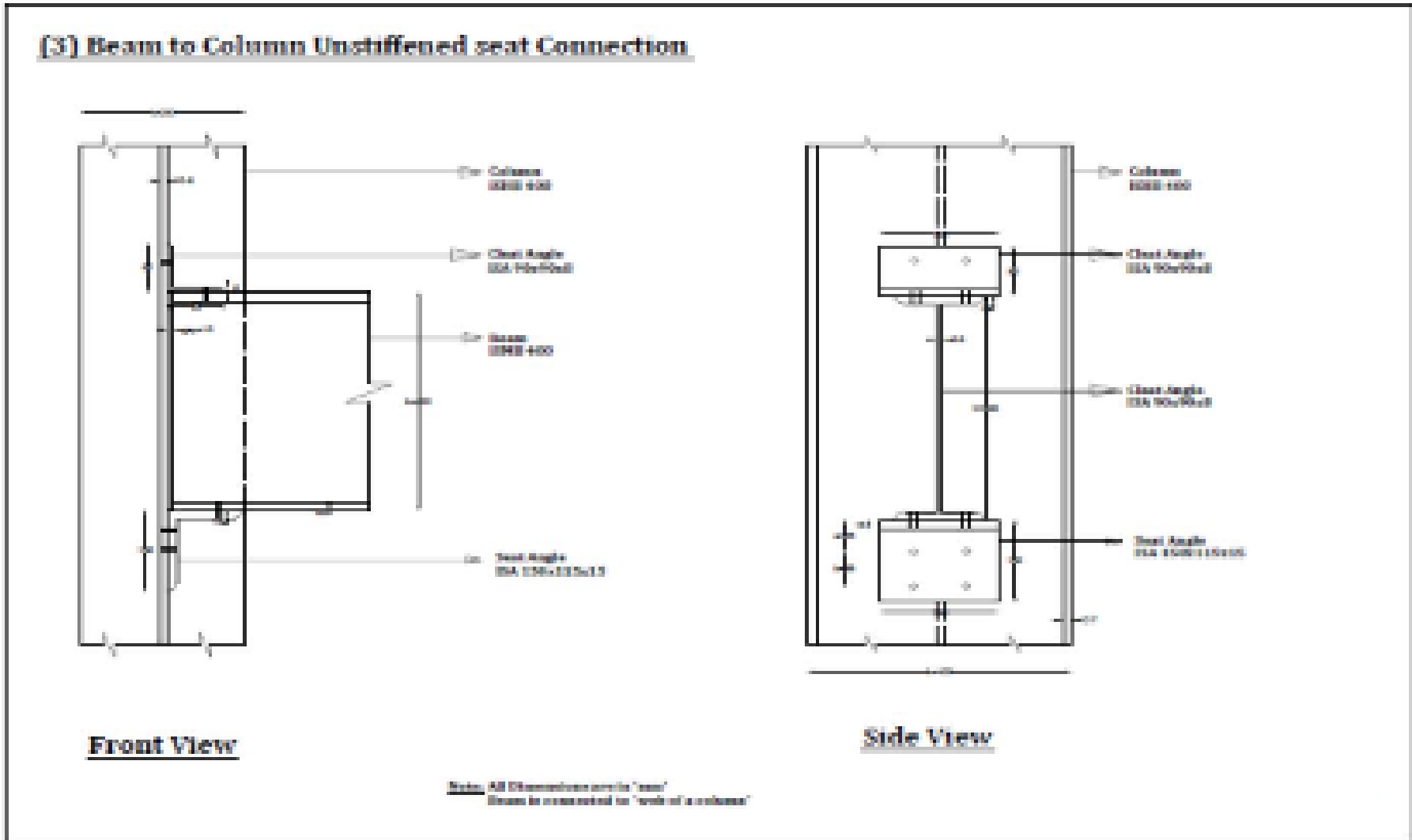

Exercise-06

**(3) Beam to Column Unstiffened seat Connection**

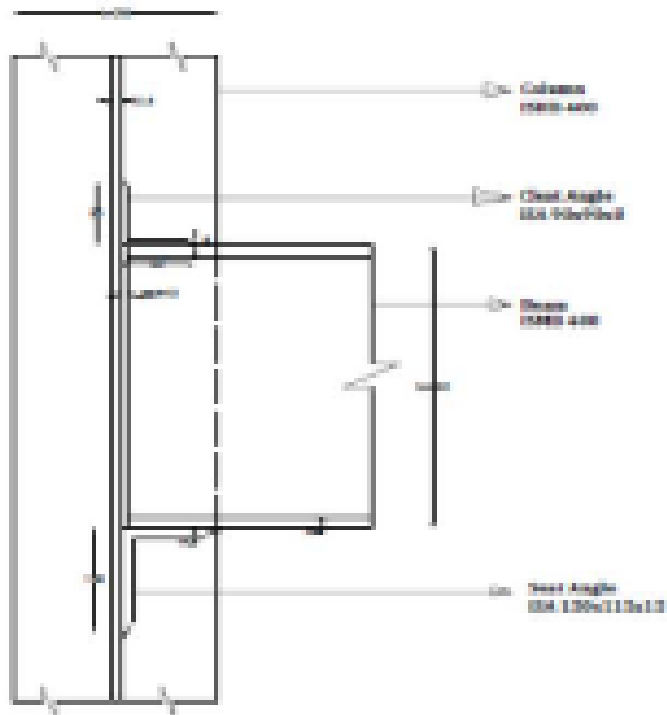

**Front View**

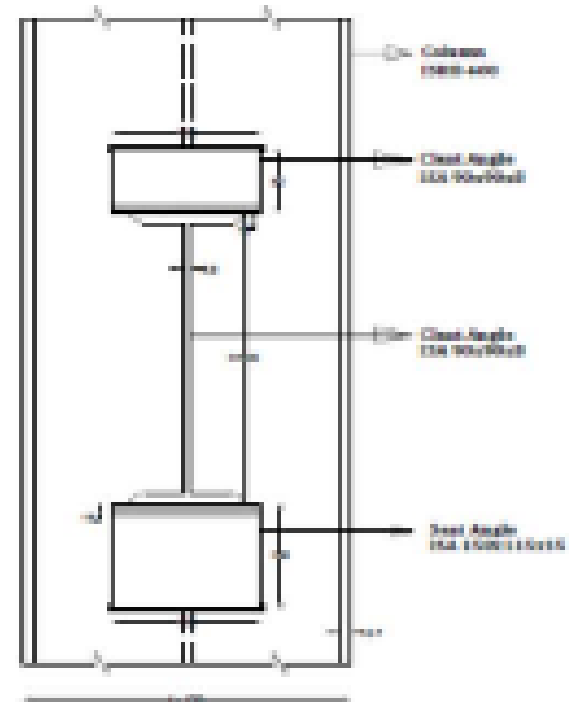

**Side View**

**Note:** All Dimensions are in 'mm'

Exercise-07

**(4) Beam to Column stiffened seat Connection**

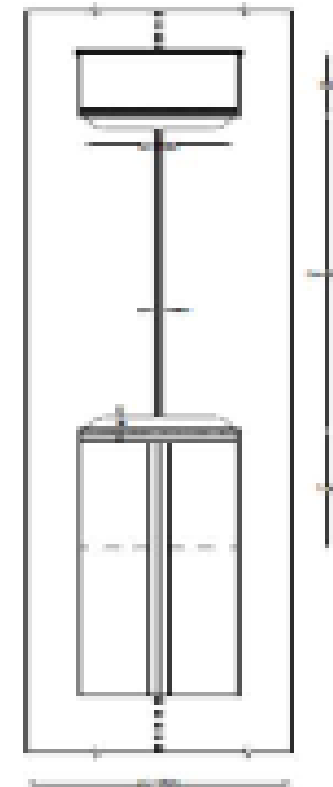
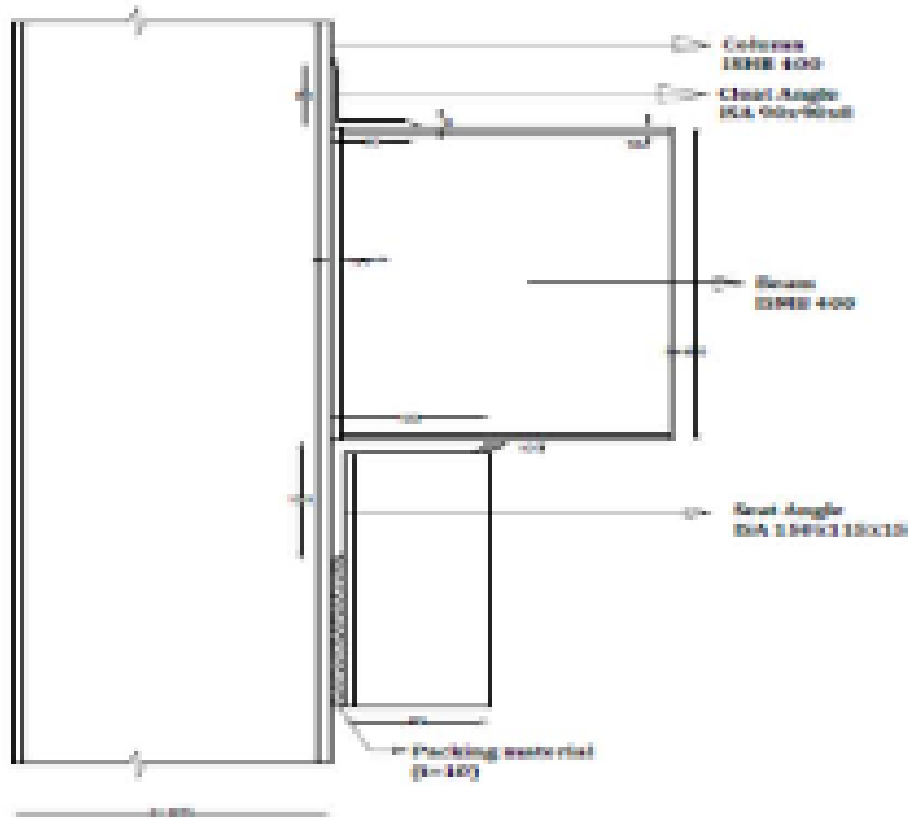

**Front View**

**Side View**

Note: All Dimensions are in 'mm'

Exercise-08

